

Name: _____ Date: _____

Volume of Composite Solids

Find the volume of each of the following composite functions.

1.

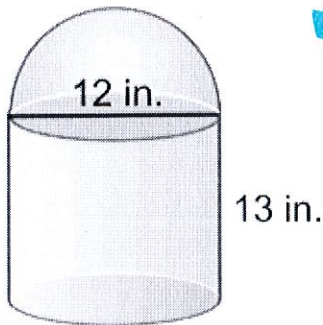

$$V_{\text{top}} = \frac{4}{3}\pi(6)^3 = 144\pi$$

$$V_{\text{bottom}} = (\pi 6^2)(13) = 468\pi$$

$$V_{\text{total}} = 144\pi + 468\pi = 612\pi = 1922.7$$

2.

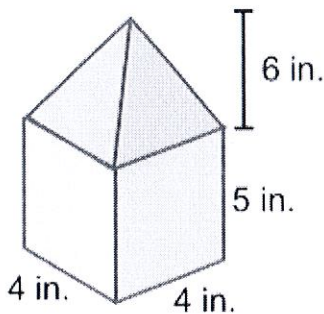

$$V_{\text{top}} = \frac{1}{3}(4 \cdot 4)(6) = 32$$

$$V_{\text{bottom}} = (4 \cdot 4)(5) = 80$$

$$V_{\text{total}} = 32 + 80 = 112$$

3.

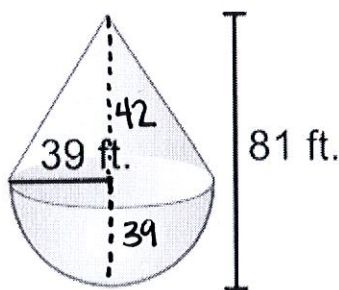

$$V_{\text{top}} = \frac{1}{3}(\pi(39^2))(42) = 21,294\pi$$

$$V_{\text{bottom}} = \frac{4}{3}\pi(39)^3 = 39,546\pi$$

$$V_{\text{total}} = 21,294\pi + 39,546\pi = 60,840\pi = 191,134.5$$

4.

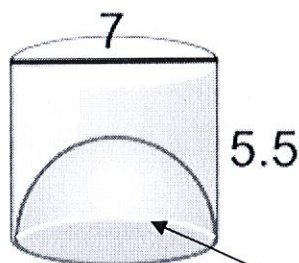

$$V_{\text{top}} = (\pi 3.5^2)(5.5) = \frac{539\pi}{8}$$

$$V_{\text{bottom}} = \frac{4}{3}\pi 3.5^3 = \frac{343\pi}{12}$$

$$V_{\text{total}} = \frac{539\pi}{8} - \frac{343\pi}{12} = \frac{931\pi}{24} = 121.9$$

Open hemisphere

5. Tennis balls with a 3 inch diameter are sold in cans of three. The can is a cylinder.

a) What is the volume of one tennis ball?

$$r = 1.5 \quad \frac{4}{3} \pi (1.5)^3 = \frac{9\pi}{2} = 14.14$$

b) What is the volume of the cylinder?

$$r = 1.5 \quad h = 9 \quad (\pi (1.5)^2)(9) = \frac{81\pi}{4} = 63.6$$

c) How much space is not occupied by the tennis balls in the can?

$$V_{\text{cylinder}} - V_{3 \text{ tennis balls}} \\ \frac{81\pi}{4} - 3 \left(\frac{9\pi}{2} \right) = \frac{27\pi}{4} = 21.2$$

6. One hot day at a fair you buy yourself a snow cone. The height of the cone shaped container is 5 in and its radius is 2 in. The shaved ice is perfectly rounded on top forming a hemisphere.

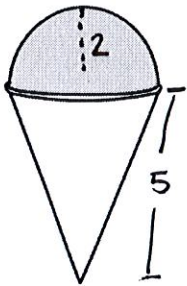

$$V_{\text{top}} = \frac{2}{3} \pi (2)^3 = \frac{16\pi}{3}$$

$$V_{\text{bottom}} = \frac{1}{3} (\pi 2^2)(5) = \frac{20\pi}{3}$$

What is the volume of the ice in your frozen treat?

$$V_{\text{total}} = \frac{16\pi}{3} + \frac{20\pi}{3} = 12\pi = 37.7$$